

Label Applicator 360a Serie

Ideal for applying pressure-sensitive labels to moving products on a production line

The CTM Labeling Systems' 360a Series Modular Labeling System is a high-speed Applicator used to apply pressure sensitive labels to moving products on a production line. It is essentially a self-contained Module that may be mounted in almost any position to apply labels to the top, bottom, or sides of packages as they pass by on a production line.

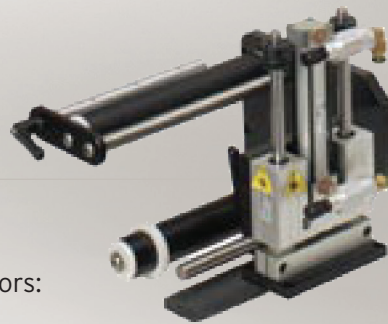
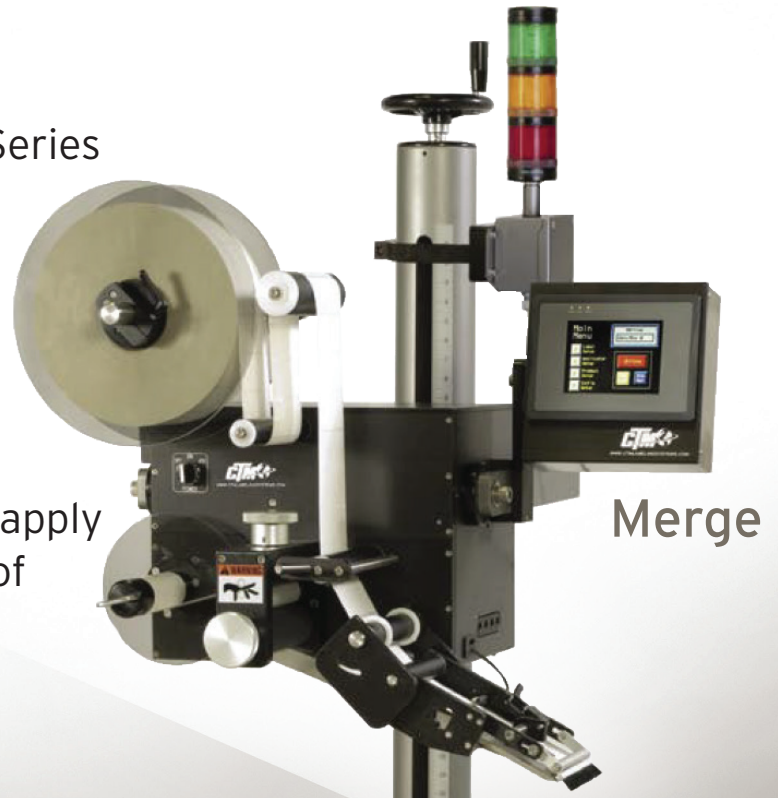

FONCTIONNALITÉS

- Can be adapted to three different types of Applicators: Air Blow, Merge, or Tamp
- Allows labels to be dispensed to the right or left side of the Applicator
- Label widths: 0.75" à 7.5" (Air Blow) ou de 0.75" x 10" (Merge et Tamp)
- Accurate : Label placement is +/- 0.03125"



Label Applicator 360a Serie

Efficient. Reliable. Made in the USA.

	Merge Module	Tamp Module	Air blow Module
Size (LxWxH)	29" x 25" x 27.5"	28" x 22.5" x 27.5"	28" x 24" x 27.5"
Voltage	120 VAC, 50/60 Hertz, Single Phase, 5 amps		
Label size	min 0.75" à 0.75" max 10" x 20"	min 0.75" à 0.75" max 10" x 10"	min 0.75" à 0.75" max 7.5" x 9"
Labeling Speed	Up to 3000 inches per minute		
Max Roll Diameter	Standard: 12" with 3" core Optional : 16" or 20" with 3" ou 6" core		
Max Roll Weight	None		
Actuation	Touch screen		